

Multi-Battery Isolator with Regulator Sensing



Waytek Stock No.	Sure Power Stock No.	Amps	Number of Studs & Size	Mounting Holes	Dimensions
80079	702R	70	4 studs at 6mm	4 holes at .21"	3.25Lx4.5Wx3.26H

Features:

- 6-50 Volts DC
- 199.4°F (93 °C) to -40 °F (-40°C) Ambient
- 500V 60 HZ AC MIN
- Negative Ground Type
- Finish: Blue anodized
- Mounting hardware included

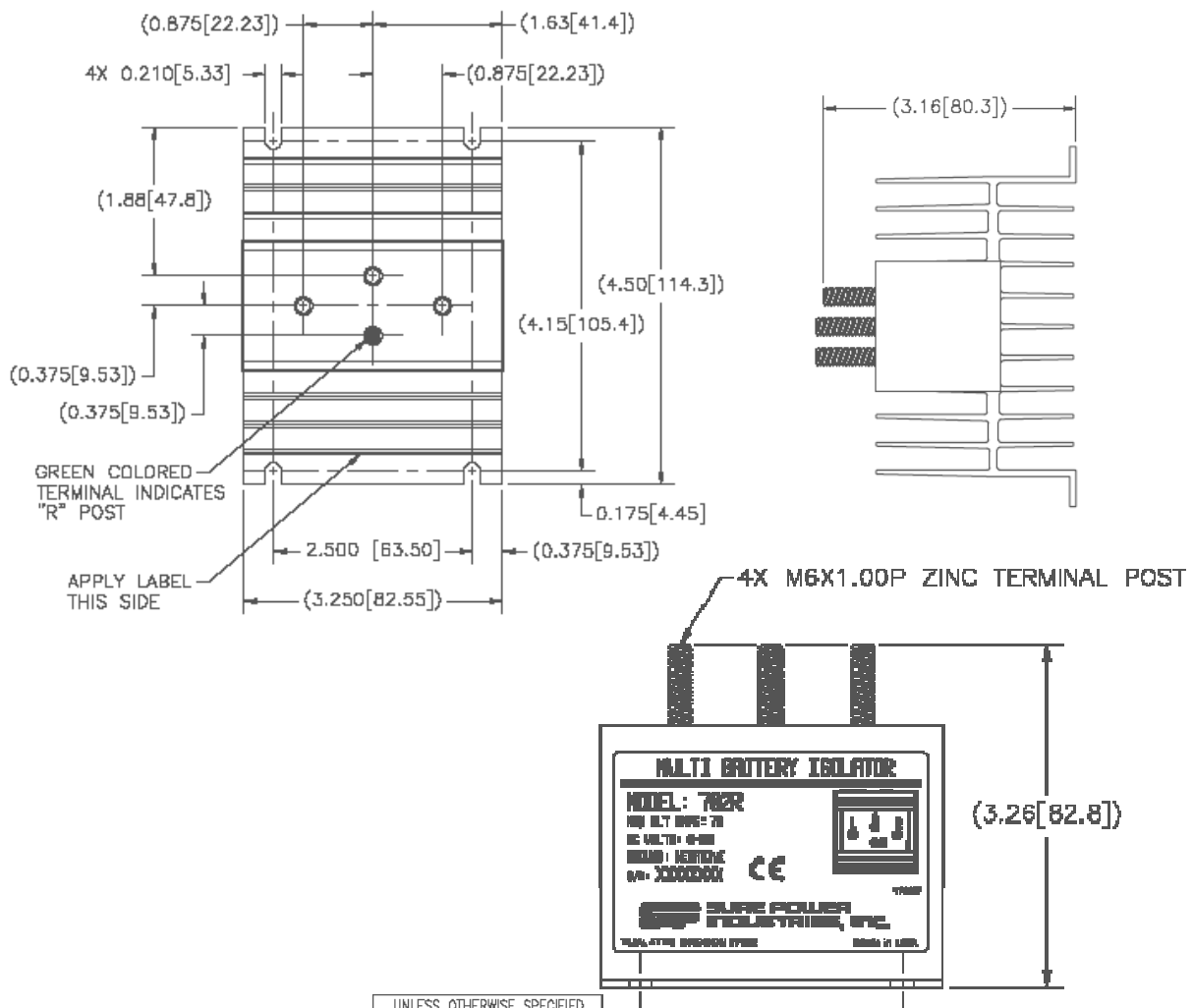

UNCONTROLLED DOCUMENT
 All information is provided by manufacturer.
 Updated 8/16/2010

UNLESS OTHERWISE SPECIFIED
 DIMENSIONS ARE IN INCHES [MM]
 TOLERANCES ARE:
 .XX ± 0.10 [X ± 2.5]
 .XXX ± 0.030 [XX ± 0.76]
 ∠ ± -
 DO NOT SCALE THIS DRAWING

www.waytekwire.com
 Phone | 800.328.2724 | 952.949.0765
 Fax | 800.858.0319 | 952.949.0965

MULTI-BATTERY ISOLATOR APPLICATION & INSTALLATION INSTRUCTIONS

(For inboard and outboard marine applications refer to instruction [180119](#) - Marine Isolator Installation Instructions section at www.surepower.com)

The installation of a Sure Power Multi-Battery Isolator is quite simple as long as you carefully read and understand these instructions, and most importantly review the application chart below before you begin.

To choose the proper battery isolator for your application the vehicle alternator type is very critical, so verify the alternator you have. Contact Sure Power Industries technical support 503-692-5360 to help verify your alternator/isolator application. The make and model number of alternator is required.

First, make sure you have all the [tools, wire, connectors and circuit breakers](#) you will need. Sure Power offers a range of installation wiring kits which make the job a snap. See the table that follows for the recommended wire size and circuit breaker for your installation.

For optimum system performance it is recommended that a battery labeled "Deep Cycle" be used in the auxiliary position.

Finally, Sure Power Multi-Battery Isolators are designed for the alternator systems with negative ground, and batteries of the same nominal voltage. Batteries of differing voltages cannot be used. For positive ground systems, marine outboard systems, or heavy-duty truck systems contact Sure Power's technical support for the proper isolator for your specialized application.

Battery Isolators

PLEASE READ INSTRUCTIONS COMPLETELY PRIOR TO STARTING INSTALLATION

80045 80046 80047 80050 80051 80061 80062 80083	GROUP 1	General Motors (Delco/Delphi)	Up to 1995 General Motors applications using the SI and DI series alternators. Except for 1985 to current General Motors Vehicles using the Delco/Delphi CS/CS 130D and AD series alternators. See group 2 for 1985 and newer applications.
		Ford	Up to 1998 and newer Ford Motorcraft alternator systems having the three wire plug connector. Call Sure Power Industries for a separate set of instructions and modification procedure for the two-plug alternator system that does not have an output bolt. Instruction #180145
		Chrysler	All models, all years including Nippondenso externally regulated alternators. Except Dodge Sprinter using Bosch alternators (not compatible with battery isolators, use battery separator-see group 4).
		Jeep	Equipped with Nippondenso externally regulated alternators.
		Japanese Imports	With alternators using external voltage regulator or external sensing. When in doubt check terminal connector label designation and call Sure Power Technical Support (503-692-5360) to help identify what alternator is on the vehicle.
		Motorola	Load Handler series or 8EM remote sense series. Some Motorola alternators may need the regulator sensing terminal type isolator. (See group 3)
		80066 80067 80068 80069 80070 80071	GROUP 2
For General Motors application: Unplugging the plug-in connector from the alternator and counting the number of terminals in the cavity of the alternator can help identify the type of alternator.			
*** The Delco Delphi CS 130-D alternator has four pin terminals the same size. The CS and AD series will have three small and one large pin terminal. The early SI series will have two spade terminals in the alternator cavity. After 2005 some General Motors alternators have a two spade connector which is not compatible with battery isolators.			
Jeep	Vehicles equipped with the Delco/Delphi CS series alternator (most 1985-1990).		
Toyota, Honda & some Imports	1985 and newer equipped with Nippondenso alternator with internal regulators or alternators with a "S" terminal. Some Honda's are not compatible with isolator. Verify alternator type.		
Ford	Many 1998 and newer Ford applications (to identify if the alternator falls into the group 2 category confirm the plug has two wires going into the plug connector). See page 3. All Group 2 Isolators will have a colored terminal indicating the "E" Terminal verify label.		
80079 80081 80082	GROUP 3	Motorola	Other than Load Handler Series, requiring regulator sensing.
		Bosch	Requiring regulator sensing.
		A group 3 isolator will have a colored fourth terminal indicating the "R" terminal. When in doubt of alternator type, call Sure Power Industries with alternator make and model number. If application is a Dodge Sprinter using the Bosch alternator, a battery isolator is not compatible. Use of a Battery Separator is recommended (verify alternator size in amps), see group 4	
GROUP 4	If the alternator is not compatible with battery isolators a Battery Separator would be the next alternative. Alternators with internal voltage sensing, e.g. some Mitsubishi and Hitachi, or single wire self-exciting Delco/Delphi alternators, some Honda's and some selected imports.		
	2005 and newer General Motors applications using the Delphi alternators (may also be labeled Bosch) with two pin terminal connectors will not work with Battery Isolators (see picture on top of page 3); use Battery Separator. NOTE: Dodge Sprinter classified under Group 4		

Special Application/
Positive Ground:

[80080](#)
[80089](#)

MAXIMUM ALTERNATOR RATING	RECOMMENDED WIRE SIZE / CIRCUIT BREAKER			
	Up to 15ft	15ft to 20ft	20ft to 25ft	25ft to 30ft
70 Amps	#8 ga. / 50 Amp	#8 ga. / 50 Amp	#6 ga. / 50 Amp	#6 ga. / 50 Amp
95 Amps	#8 ga. / 50 Amp	#6 ga. / 50 Amp	#4 ga. / 50 Amp	#4 ga. / 50 Amp
130 Amps	#6 ga. / 80 Amp	#4 ga. / 80 Amp	#2 ga. / 80 Amp	#1 ga. / 80 Amp
160 Amps	#4 ga. / 120 Amp	#2 ga. / 120 Amp	#2 ga. / 120 Amp	#0 ga. / 120 Amp
240 Amps	#000 ga. / 150 Amp	#000 ga. / 150 Amp	#0000 ga. / 150 Amp	#0000 ga. / 150 Amp

Go to www.waytekwire.com for wire, circuit breakers options.

UNCONTROLLED DOCUMENT
All information is provided by manufacturer.
Updated 9/16/2010

www.waytekwire.com
Phone | 800.328.2724 | 952.949.0765
Fax | 800.858.0319 | 952.949.0965

SPECIAL INSTRUCTIONS FOR GROUP 2 ALTERNATORS

General Motors Delcotron/Delphi Plug Identification & Installation Procedure

Starting in 2005 and newer General Motor's applications using the delphi alternators with two pin connectors will not work with battery isolators. (See below for plug connector identification).

When installing an isolator on a GM "CS" series alternator equipped vehicle the general isolator installation instructions on page 2 of the instruction sheet must be followed in addition to the group 2 instructions as shown here. However, this alternator requires external excitation and external sensing. An isolator with an excitation terminal "E" and a plug connector kit (80093/144-C) are required. There are two styles of connectors used on GM vehicles from 1985 to 2006. These are the CS, CS130D and AD series. See Instruction 180064 for plug modification.

NOTE: If the existing Delco/Delphi connector has a wire in the "S" position of the standard CS alternators or a wire in the "D" position on the CS 130D connector, the replacement or modification of the plug is not necessary but the excitation on the isolator still needs to be implemented. Proceed to step 3 below after plug has been modified or if a sense wire is already available.



SFLP
If the mating side of the connector looks like this: Refer to instruction 180064, page 2. CS series most common on 1988 and later vehicles.



ABCD
If the mating side of the connector looks like this: Refer to instruction 180064, page 1. CS130D most common on 1993 and later vehicles.



Not compatible with battery isolators.

Please follow steps 1-4 below after completing page 1 or page 2 of instruction 180064.

1. Reconnect the new plug into the alternator.
2. Route the remaining sense wire of the plug-in connector to terminal #1 of the Sure Power isolator. Cut to the correct length, strip and crimp on the 1/4" ring terminal supplied. Now connect to terminal #1 of the isolator along with wires from step 4 of general installation instructions. This becomes the voltage sense wire.
3. External excitation connection. The "E" post of the isolator requires connection to an ignition switched source such that power is applied only in the ignition/run position. BE SURE POWER IS NOT APPLIED WHEN IGNITION IS SWITCHED TO ACCESSORY POSITION. On most late GM vehicles this point may be one of the spare ignition terminals marked "IGN" on the fuse center. Connect one end of the yellow wire supplied to one of these spare ignition terminals. Route the other end of the yellow wire to the "E" terminal of the isolator. (If using the recommended 6-amp circuit breaker (supplied with the 144-C Kit) insert the circuit breaker in the yellow wire as shown in the diagram.) Cut to the correct length, strip and crimp on the supplied ring terminal. Now connect the yellow wire to the "E" terminal of the isolator with the lock washer and nut. Colored terminal indicates "E" post on the isolator.
4. Now proceed to step 8 of the general isolator installation instructions on page 2.

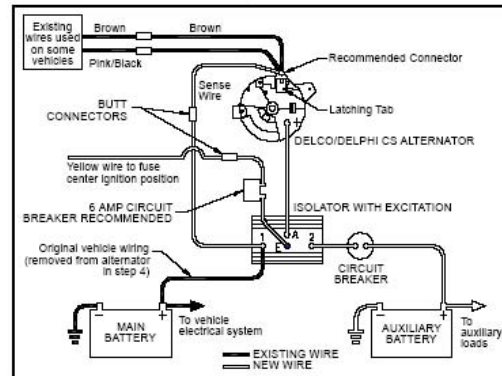

NOTE: Some Hondas and some selected imports will not work with battery isolators. Verify alternator type by identifying terminals on alternator.

TOYOTA, SOME HONDAS & IMPORTS

Using internally regulated Nippondenso alternators with remote sense only, check alternator terminal designation on alternator. When installing an isolator to a Toyota alternator, follow general installation instructions (page 2) in addition to the following steps.

1. Locate the small ignition wire terminal labeled "IGN" that runs from the alternator to the wiring harness. Check that you have the right wire by stripping a small section of the wire and determining that voltage is present only when the key is in the "run" position but not in the "accessory" position. Do not interrupt wire.
2. After completing steps 1-9 of general instructions, connect an excitation wire from the point located in step #1 above, to the "E" terminal of the isolator. Colored terminal indicates "E" post. Sure Power recommends a 6-amp circuit breaker (Sure Power Model 1506) be inserted in this line.

NOTE: The group 2 isolator may be used in applications not requiring the excitation by not connecting the "E" terminal.

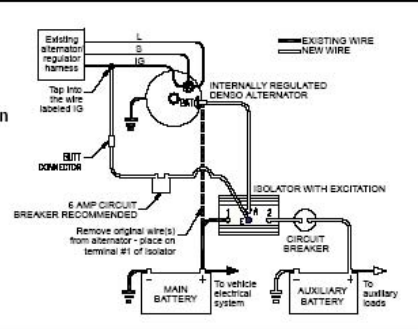

1998 & LATER FORD APPLICATIONS

NOTE: This procedure is an additional step for some 1998 and newer Ford applications. Group 1 general instruction on page 2 of instruction sheet 180012 must be followed in addition to this instruction. One way to check to see if this procedure needs to be done is to check the plug connector. If the connector has only two wires in the plug connector then the "E" terminal needs to be used to excite the alternator through the isolator.

After completing steps 1-9 of the general instructions, connect a new wire from the "E" terminal of the isolator to a 6-amp circuit breaker, then to an ignition run connection in the fuse center. Colored terminal indicates "E" post. Sure Power recommends a 6-amp circuit breaker (Sure Power Model 1506) be inserted in the line.

NOTE: the group 2 isolator may be used in applications not requiring the excitation by not connecting the "E" terminal.

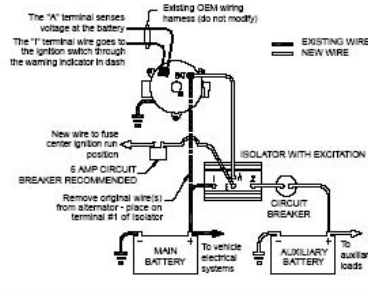

GROUP 3 ALTERNATORS

Carefully review the individual schematics shown below and then follow the specific installation instructions relative to the type of alternator and vehicle with which you are working.

FOR BOSCH ALTERNATOR USING ALTERNATOR MOUNTED REGULATOR SYSTEM (AS USED ON VOLKSWAGEN VANAGONS).
FOR EXTERNAL MOUNTED REGULATOR CONSULT FACTORY.

1. After completing step #4 of standard instructions, remove the two screws attaching the regulator. With great care, remove the regulator. Use a downward, rolling motion to prevent breaking off the brushes.
2. Bend the connector prong of the alternator, as illustrated, so that it will not longer mate with the internal connection strap of the regulator. (The regulator connector may need to be bent also to insure no contact.)
3. Solder an appropriate length of #14 wire to the regulator connector prong, as was bent in step #2 (see illustration).
4. Replace regulator, Note: suggest a flat blade to hold the brushes in the holder until the regulator is in place. Replace mounting screws (route wire so it will not be pinched or in the way).
5. Connect the other end of the wire that was soldered on the regulator to the "R" terminal on the isolator. Colored terminal indicates "R" post.
6. Disconnect the wire(s) going to the D+ terminal of the alternator.
7. Reconnect these same wire(s) to the "R" terminal of the isolator with the wire connected in step #5 above.
8. Now proceed to step #5 of the GENERAL ISOLATOR INSTALLATION INSTRUCTIONS on page 2.

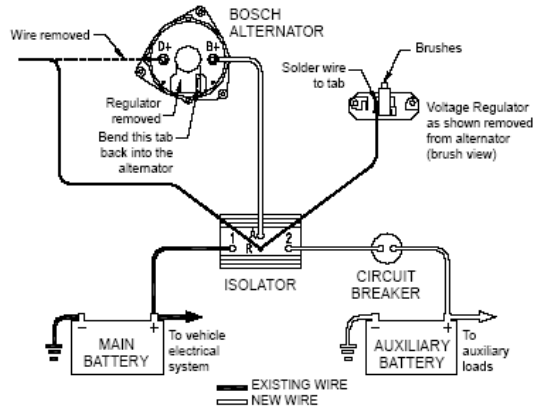

ELECTRICAL TEST:

1. **Engine not running:** #1 terminal of isolator should read vehicle battery voltage. #2 terminal should read auxiliary battery voltage. The "A" terminal may read from zero to 13 volts. The "E" terminal on 3A series isolators (group 2) should read zero volts, the "R" terminal on "R" series isolators (group 3) should read from zero to 13 volts.
2. **Engine running and alternator charging:** #1, #2, and "E" terminal on 3A isolators (group 2) should read voltage regulator setting of approximately 13.8 to 14.5 volts. The "R" terminal on "R" series isolators (group 3) should also read voltage regulator setting. The "A" terminal on 3A series isolators (group 2) and "R" terminals on "R" series isolators (group 3) voltage should read 0.8 to 1.0 Volt higher than the reading of the #1, #2 terminals and "E" terminals.
3. For 12 volt systems the "A" post should read approximately 14.8 to 15.5 volts. The #1 and #2 terminal should read 13.8 to 14.5 volts. If the "A" terminal reads 13.8 to 14.2 volts the regulator may be sensing the alternator output rather than the main battery. This situation needs to be corrected for proper charging of batteries.
4. Colored terminal indicates "E" post on group 2 isolators and "R" terminal on most group 3 isolators.

INSTRUCTIONS FOR TESTING A SURE POWER ISOLATOR WITH OHMMETER*:

1. Remove all wires from the isolator.
2. Using a needle movement ohmmeter RX-1 scale or a digital ohmmeter diode scale, hold the Red* probe on the terminal "A" and with the Black* probe touch terminal #1 and #2, and the "E" terminal for 3A isolators (group 2), and the "R" terminal for (group 3) isolators. A good isolator will show a current flow from "A" to #1, #2 and "R", and no current flow to "E".
3. Next, hold the Black* probe on the "A" and with the Red* probe touch terminal #1 and #2 (terminal "E" and "R", if used). A good isolator will allow no current flow from "A" to #1, #2 or "R" and will show current flow from "E" to "A".
4. Hold one probe on the aluminum heat sink, being sure there is contact by scratching through the protective coating. Then touch with the other probe, terminals "A", #1, #2 (the "E" terminal for 3A isolators [group 2], the "R" terminal for group 3 isolators). A good isolator will show no current flow.
5. Colored terminal indicates "E" post on group 2 isolators and "R" terminal on most group 3 isolators.

*On some import ohmmeters, the red and black probes are reversed for these tests.

**If using a digital ohmmeter, a diode scale MUST be used.

SURE POWER ONE-YEAR LIMITED WARRANTY.

Sure Power Industries, Inc. warrants each new product against factory defects in material and workmanship for one year after date of purchase. The owner will be responsible for removing from the vehicle and returning any defective unit(s), transportation costs prepaid to Sure Power Industries, Inc. factory or a factory authorized servicing distributor. Sure Power Industries, Inc. will, without charge, repair or replace at its option, unit(s) which its inspection determines to be defective. All transportation charges must be borne by the purchaser. A copy of the purchaser's receipt must be returned with the defective unit(s) in order to qualify for warranty coverage. Exclusions from this warranty are the finish and any condition(s) determined by Sure Power Industries, Inc. to have been caused by abnormal use or service. This warranty shall not apply to any Sure Power product which has been improperly installed.

There are no warranties, expressed or implied (including any implied warranties of merchantability or fitness), which extend beyond this warranty period. The loss of use of the product, loss of time, inconvenience, commercial loss or consequential damages are not covered. Sure Power Industries, Inc. reserves the right to change the design of any product without assuming any obligation to modify any product previously manufactured.

This warranty gives you specific legal rights. You may also have other rights which vary from state to state. Some states do not allow limitations on how long an implied warranty lasts. Some states do not allow the exclusion of limitation of incidental or consequential damages. Therefore, the above limitation(s) may not apply to you.

UNCONTROLLED DOCUMENT

All information is provided by manufacturer.

Updated 9/16/2010

www.waytekwire.com
Phone | 800.328.2724 | 952.949.0765
Fax | 800.858.0319 | 952.949.0965